

SERVICE MANUAL SUPPLEMENT

FM/AM TUNER 2083-5

Use this supplement together with the 30, 35A, 50 Service Manual for maintenance and repair of units using FM/AM Tuner 2083-5.

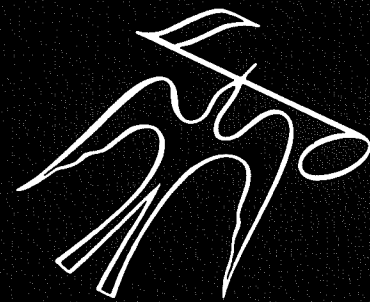

The Fisher 30 35A 50

WORLD LEADER IN HIGH QUALITY STEREO

identification of 2083-5 tuner

Tuning gang VC1 – VC5 is mounted on its side. AM trimmers TC4 and TC5 are at the top of the gang. See illustration. (On the 2083-3 tuner, the trimmers are on the side.)

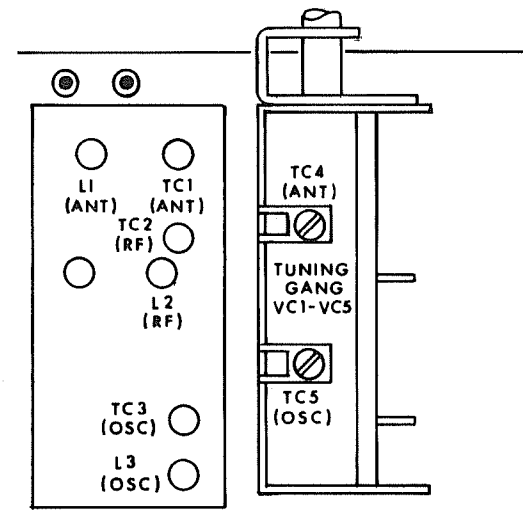

dial stringing

- (1) Remove motorboard and dress panel. Refer to REMOVING MOTORBOARD and REMOVING DRESS PANEL procedures.
- (2) Remove dial pointer from old dial cord.
- (3) Prop unit on its left side. Remove the right wood side-panel by removing the two slotted screws near the feet.
- (4) Rotate tuning capacitor drum fully CCW. Loosen machine screws in drum and remove old dial cord.
- (5) Tie end of new cord to end of spring. Fasten spring to START screw. See illustration.
- (6) Cross the cord to inside of drum, then run cord through slot in rim and wrap $\frac{3}{4}$ turn CCW around drum. Guide cord around pulley "A", and wrap 2 full turns (CCW viewed from back) around tuning shaft.
- (7) Guide cord over pulley "B" and around pulleys "C" and "D". Rotate drum fully CW allowing cord to wind on drum.
- (8) Run cord under drum and around the other side into the rim slot. Wrap cord around FINISH screw.
- (9) Pull cord taut and tighten screw. Turn tuning shaft CW and CCW to distribute tensioning.
- (10) Repeat (9) until spring is tensioned.
- (11) Place pointer on rail and slip cord under tabs. Turn tuning shaft fully CCW. Slide pointer to (0) mark and cement to cord.
- (12) Check dial calibration.
- (13) Reinstall dress panel, side panel, and motorboard.

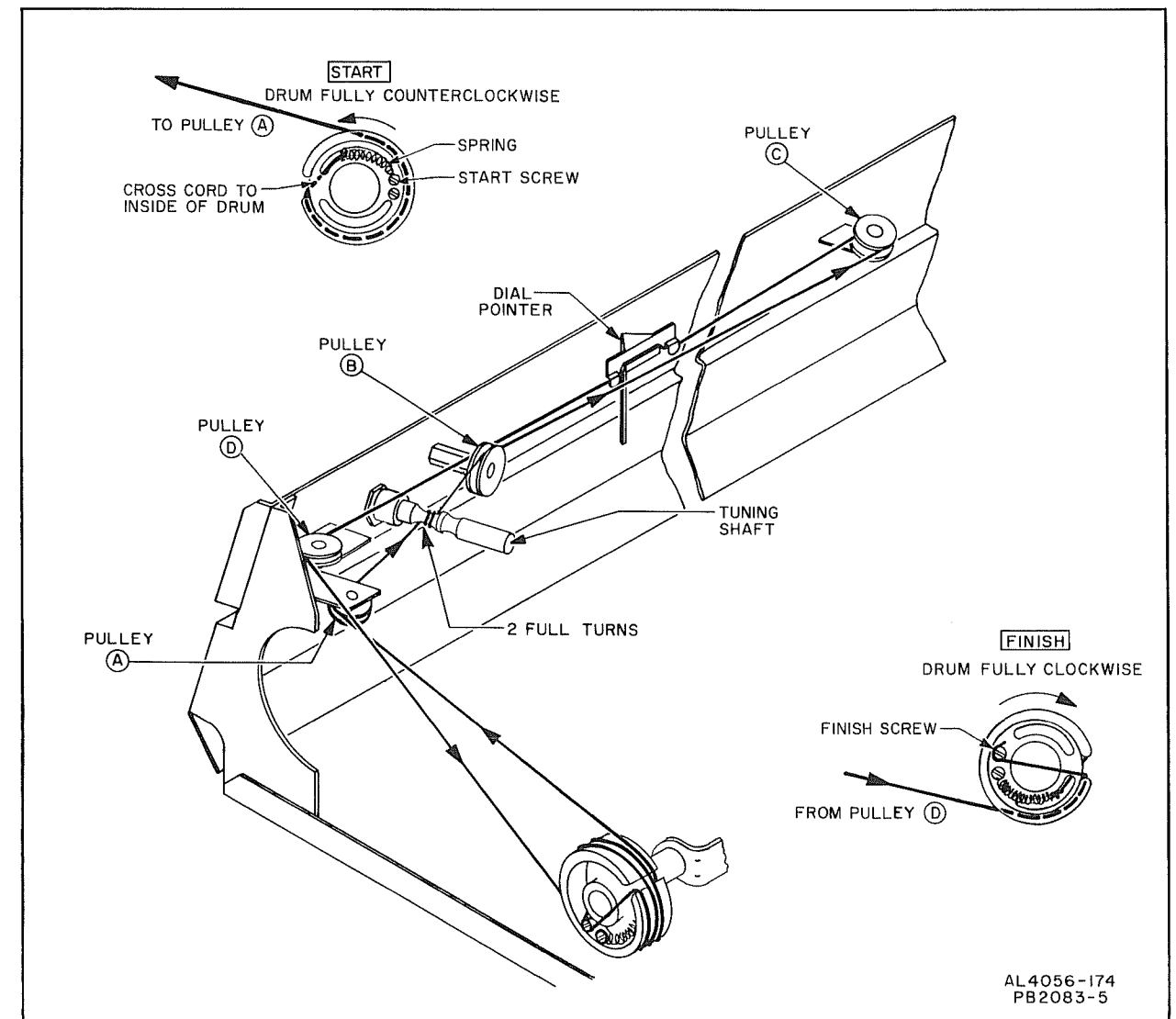

AL4056-174
PB2083-5

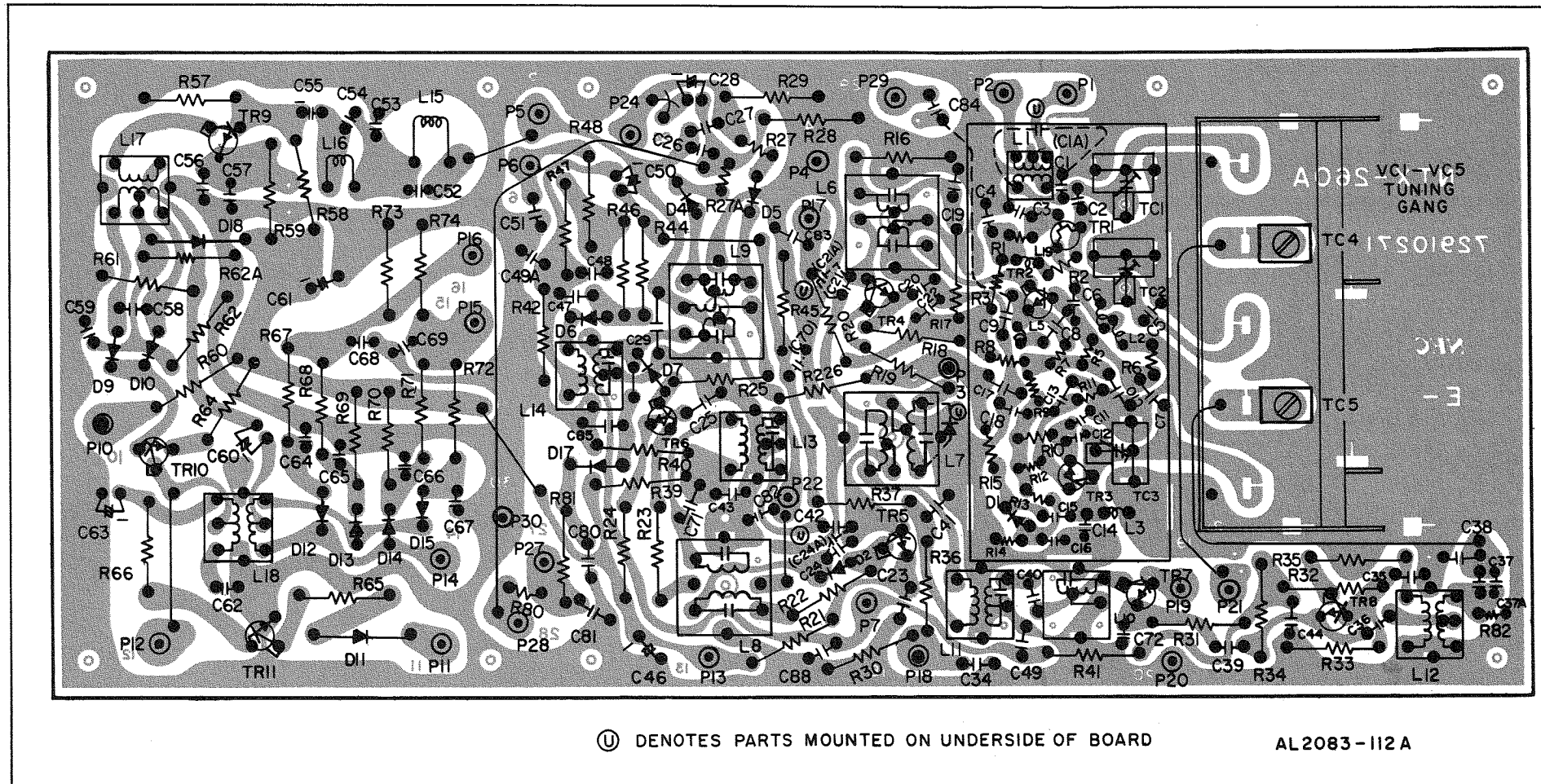

Turn TUNING knob fully CCW. If pointer is not centered on (0), reposition and cement pointer. Except as noted, maintain generator level as low as possible during alignment.

FM ALIGNMENT

- (1) Set SELECTOR switch to FM. Turn VOLUME control to minimum. Connect jumper between P3 and P4 to defeat AFC.
- (2) Connect 10.7MHz sweep generator to P29. Connect scope through 220K to P28. Open wire loop at P24.
- (3) Detune top core of L9. Adjust top and bottom cores of L8, L7, and L6, and bottom core of L9 for maximum gain and symmetry.
- (4) Reconnect wire loop at P24. Reconnect scope to P5. Adjust top and bottom cores of L9 for maximum linear amplitude.
- (5) Set sweep generator for CW output at 10.7MHz. Connect DC VTVM to P5. Readjust top core of L9 for OVDC. Disconnect sweep generator and DC VTVM and connect scope to RCDR OUT jack. Connect FM RF generator through 120-ohm carbon composition resistors to FM ANT. terminals.
- (6) Set generator frequency and dial pointer accurately to 90MHz. Modulate generator with 400 Hz, $\pm 75\text{kHz}$ deviation. Adjust core of antenna coil L1 and bend oscillator coil L3 and RF coil L2 for maximum amplitude on scope.
- (7) Set generator frequency and dial pointer accurately to 106MHz. Adjust antenna trimmer TC1, oscillator trimmer TC3, and RF trimmer TC2 for maximum amplitude on scope.
- (8) Repeat (6) and (7) for maximum sensitivity and accurate dial calibration. Disconnect scope.
- (9) Reconnect DC VTVM to P5. Set generator level to 1mV. Tune receiver to generator frequency (106MHz) for OVDC at P5.
- (10) Connect an AC VTVM to the RIGHT RCDR OUT jack, and another AC VTVM to the LEFT RCDR OUT jack.
- (11) Connect MPX generator composite output to FM generator EXTERNAL MODULATION input. Modulate left and right channels with 400Hz ($\pm 67.5\text{kHz}$ deviation/90%), and 19kHz pilot ($\pm 7.5\text{kHz}$ deviation/10%).
- (12) Adjust top cores of L17 and L18 for maximum audio.
- (13) Modulate left channel only. Right channel AC VTVM should indicate at least 20dB below left channel output.
- (14) Modulate right channel only. Left channel AC VTVM should indicate at least 20dB below right channel output.
- (15) Disconnect MPX generator. Set RF generator output to 20mV, and modulate with 400Hz, $\pm 75\text{kHz}$ deviation.
- (16) Detune generator frequency for +0.5VDC at P5. Disconnect jumper between P3 and P4 to turn AFC on. DC VTVM should indicate OVDC $\pm 200\text{mV}$.
- (17) Reconnect jumper between P3 and P4 and detune generator for -0.5VDC at P5. Remove jumper. Meter should indicate OVDC $\pm 200\text{mV}$. Disconnect test equipment.

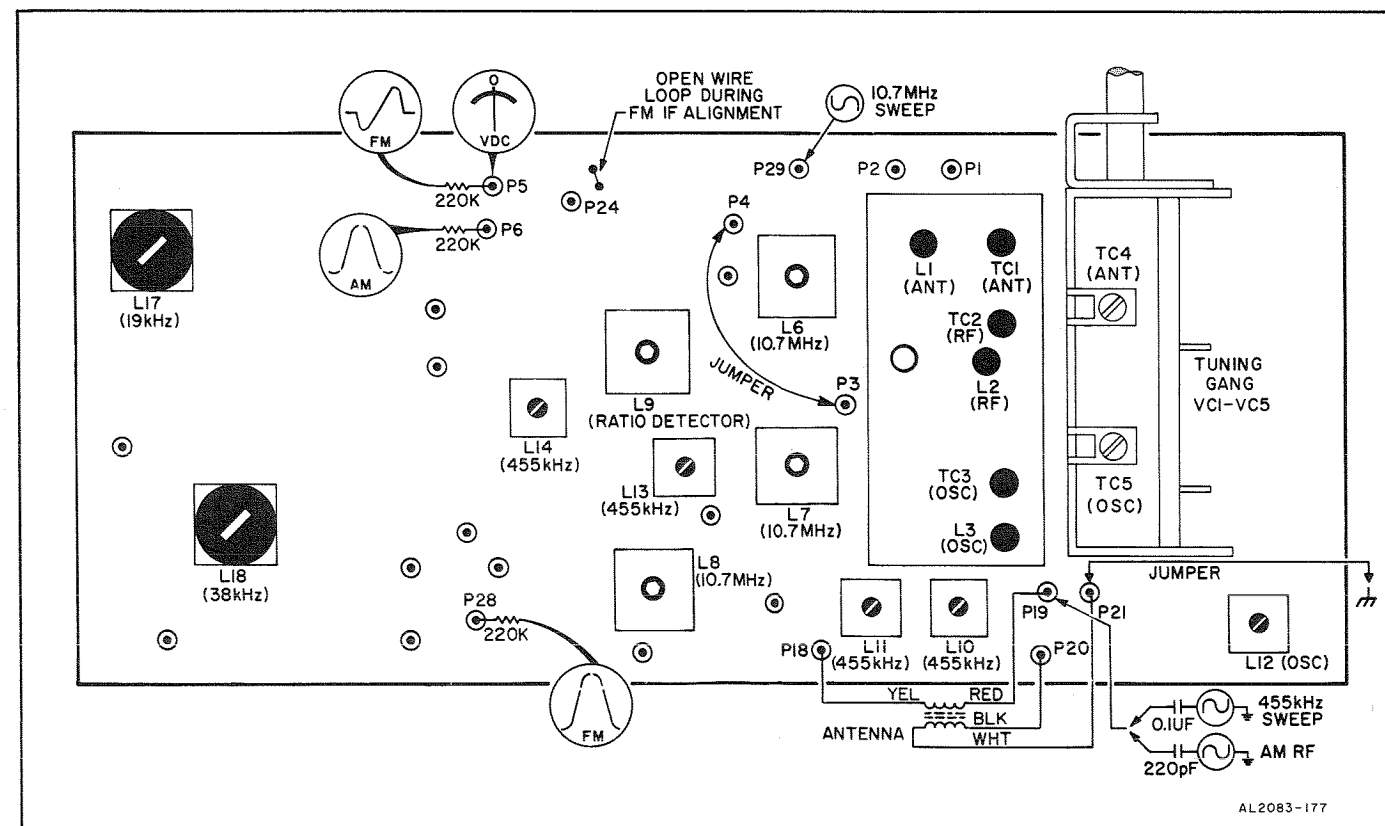

AM ALIGNMENT

- (1) Set SELECTOR switch to AM. Turn VOLUME control to minimum.
- (2) Connect 455kHz sweep generator through 0.1uF to P19. Connect scope through 220pF to P6.
- (3) Adjust cores of L14, L13, L11, and L10 for maximum gain and symmetry.
- (4) Disconnect sweep generator. Connect AM signal generator through 220pF to P19. Connect scope and AC VTVM to RIGHT RCDR OUT jack.
- (5) Set generator frequency and dial pointer accurately to 600kHz. Modulate generator with 400Hz, 30% modulation. Connect a short jumper between P21 and chassis. Adjust oscillator coil L12 for maximum amplitude.
- (6) Set generator frequency and dial pointer accurately to 1400kHz. Adjust oscillator trimmer TC5 for maximum amplitude.
- (7) Repeat (5) and (6) for accurate dial calibration and maximum gain.
- (8) Disconnect jumper connection P21 and chassis. Reconnect AM signal generator to AM ANT. terminal. Open GND link. Tune receiver to generator frequency at 600kHz. Modulate generator with 400Hz, 30% modulation.
- (9) Melt the wax holding the coil to the ferrite antenna. Shift the coil for maximum audio indication. To secure coil in position, remelt wax.
- (10) Tune receiver to generator frequency at 1400kHz. Adjust antenna trimmer TC4 for maximum audio.

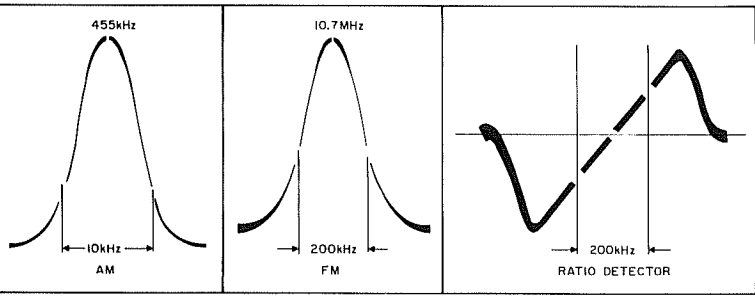
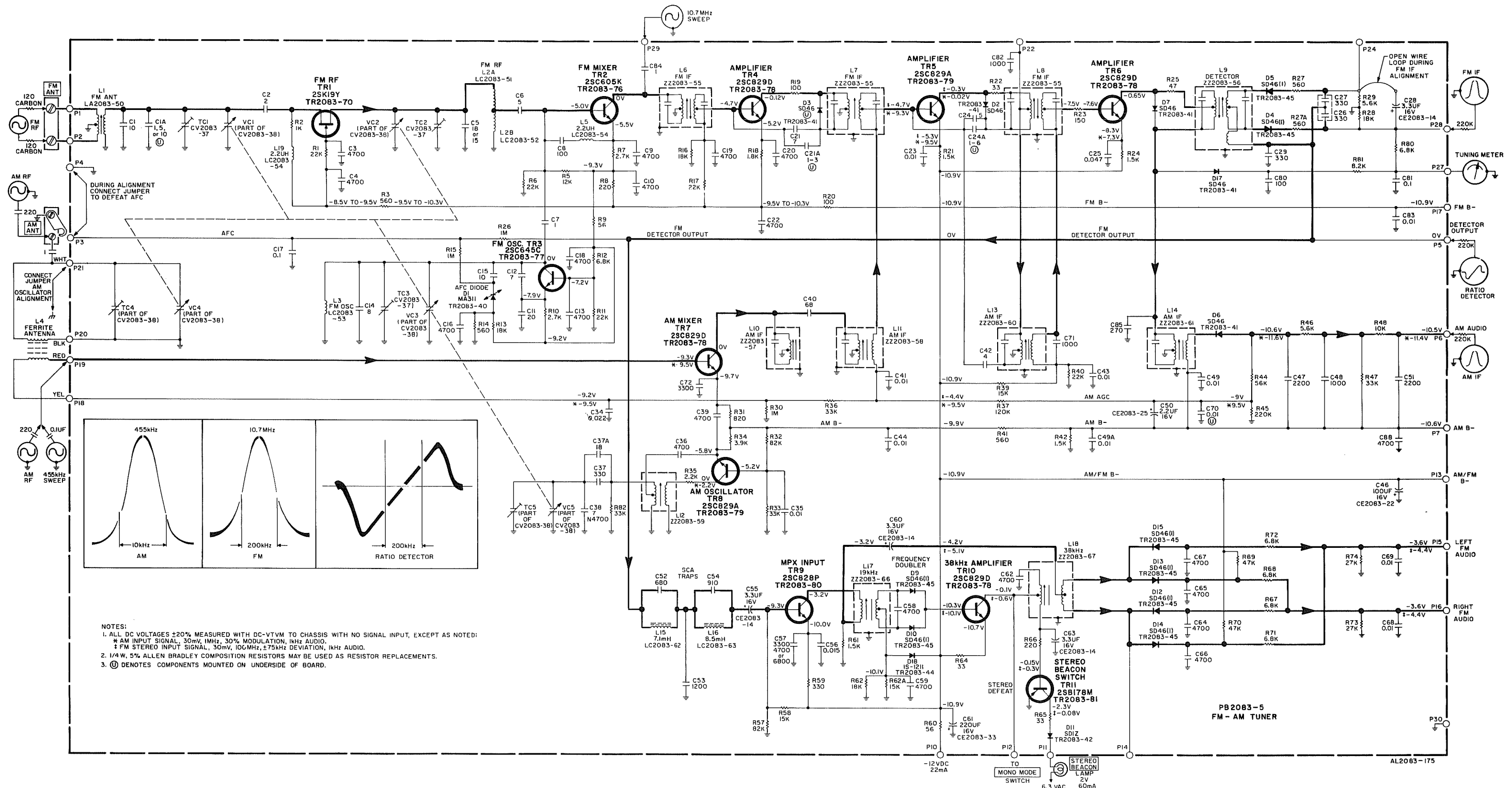

- NOTES:
1. ALL DC VOLTAGES $\pm 20\%$ MEASURED WITH DC-VTVM TO CHASSIS WITH NO SIGNAL INPUT, EXCEPT AS NOTED:
 * AM INPUT SIGNAL, 30mV, 1MHz, 30% MODULATION, 1kHz AUDIO.
 † FM STEREO INPUT SIGNAL, 30mV, 100MHz, ± 75 KHz DEVIATION, 1kHz AUDIO.
 2. 1/4W, 5% ALLEN BRADLEY COMPOSITION RESISTORS MAY BE USED AS RESISTOR REPLACEMENTS.
 3. Ⓢ DENOTES COMPONENTS MOUNTED ON UNDERSIDE OF BOARD.

PB2083-5
FM - AM TUNER

FISHER RADIO • LONG ISLAND CITY • NEW YORK 11101

NL4056-103

8M32